

### Before assembly

- We recommend that time is taken to read the instructions before starting assembly, then follow the easy step by step guide. The instruction sheet is only a guide to the assembly. Certain items may not be shown to scale.
- Check all components prior to assembly
- This product should be assembled by no less than 2 people.
- Never attempt to erect the assembly in high winds.
- Drill components where indicated.
- Some of the components may have sharp edges wear protective work gloves while handling components.

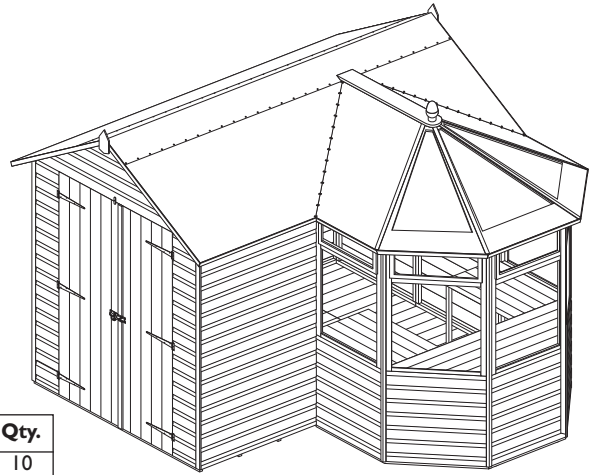

No.	Components	Qty.
1	Large floor panel	2
2	Small floor panel	1
3	Angled floor panel	1
4	Large back wall panel (1890x1174mm)	2
5	Small back wall panel (1890x600mm)	1
6	Front wall panel (1890x1125mm)	1
7	End wall panel (1890x850mm)	2
8	Door end wall panel (1890x250mm)	2
9	Corner post (45 x35x1890mm)	1
10	Corner post with notch (45 x35x1890mm)	1
11	Left-hand window panel	1
12	Window panel (Opening window)	3
13	Right-hand window panel	1
14	Apex panel	2
15	Door header rail	1
16	Door rebate coverstrip	2
17	Left-hand door end roof panel (1160x1132mm)	1
18	Right-hand door end roof panel (1160x1132mm)	1
19	Left angled roof panel (1160x1140mm)	1
20	Right angled roof panel (1160x1040mm)	1
21	Left-hand roof panel (1160x1040mm)	1
22	Right-hand roof panel (1160x1040mm)	1
23	Left-hand hip roof panel (1055x965mm)	1
24	Right-hand hip roof panel (1055x965mm)	1
25	Triangular styrene roof panels	3
26	Left door (1890x662mm)	1
27	Right door (1890x525mm)	1
28	Roof block (84x45x965mm)	1
29	Roof capping (165x15x1060mm)	1
30	Internal roof capping (148x15x925mm)	1
31	Left roof join cover (85x17x925mm)	1
32	Right roof join cover (85x17x925mm)	1
33	Centre roof join cover (60x17x262mm)	1
34	Corner/joint coverstrips (48x12x1890mm)	7
35	Angled corner coverstrips (12x35x1910mm)	4
36	Angled roof coverstrips (12x35x1160mm)	4
37	Door coverstrips (12x48x920mm)	2
38	Apex bargeboards	4
39	Left-hand bargeboard	1
40	Right-hand bargeboard	1
41	Window panel bargeboards	3
42	Front panel bargeboard	1
43	Large window glazing (750x655mm)	5
44	Small window glazing (580x255mm)	5
45	Large window beading (12x30x728mm)	10
46	Large window beading (12x30x657mm)	10
47	Small window beading (15x15x555mm)	10
48	Small window beading (15x15x257mm)	10
49	Roofing felt roll (10m)	1
50	Roofing felt roll (5m)	1
51	Potting table	1
52	Side potting table	2
53	Potting table legs (29x35x740mm)	4
54	Acorn finial	1

No.	Fixing kit	Qty.
55	Roof gussets	10
56	Special finial	2
57	T-hinge (254mm)	6
58	Turn button	1
59	Pad bolt	1
60	Tower bolt	2
61	Metal L-brackets	4
62	50mm coach bolts	4
63	6mm washers	4
64	6mm nuts	4
65	63mm screws	23
66	50mm screws	130
67	38mm screws	16
68	32mm screws	50
69	25mm screws	17
70	22mm screws	8
71	19mm round head screws	12
72	30mm nails	113
73	25mm nails	136
74	10mm felt nails	232

### Recommended tools for assembly

- Cross head screw driver
- Hammer
- Sharp knife
- Drill
- 3mm diameter drill bit
- 6mm diameter drill bit
- Spirit level
- Silicon sealant
- Step ladder
- Prop

### Footprint

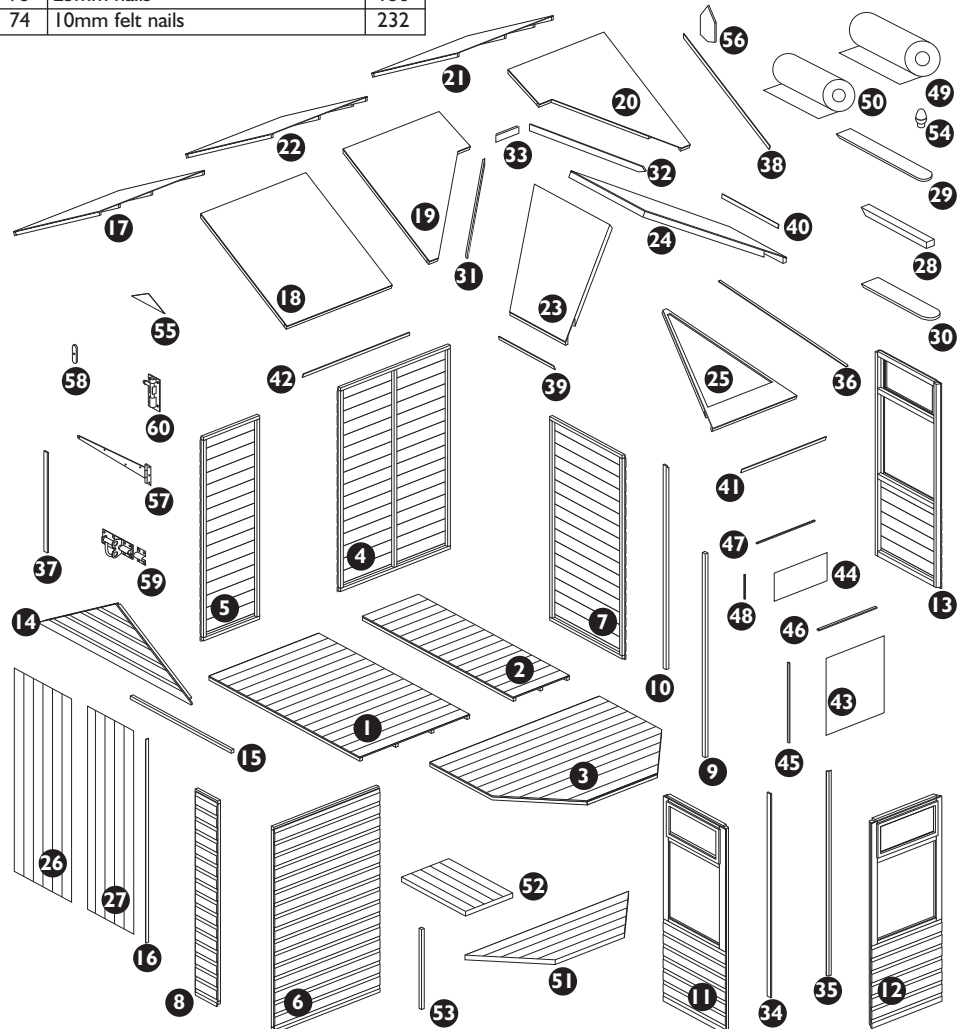
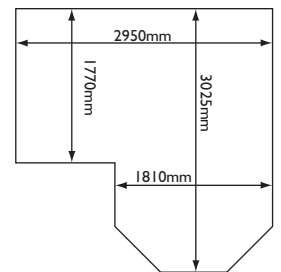

## 1. Floor panels

Prepare a level area for the shed to sit. With the three rectangular floor panels upside down, join them together using 4 x 50mm screws for each join. Turn the floor up the right way and place into position. Place the floor side extension piece either to the right or left of the side edge of the main floor. Check that the whole floor is sitting level.

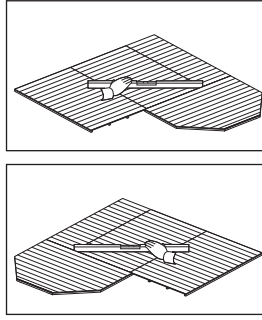
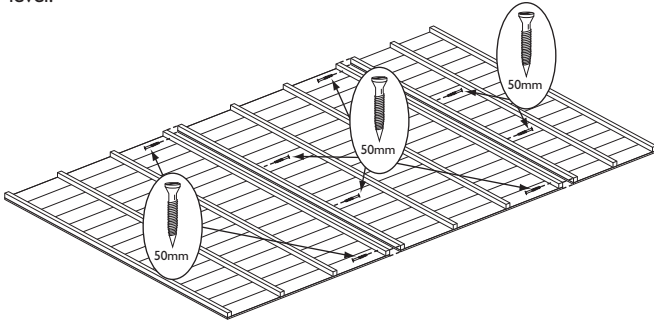

### Important note

To "VALIDATE" the guarantee, adequate provision must be made to ensure ground contact is avoided and air is able to circulate underneath the building. Placing the building on a concrete pad or slab base is acceptable provided that the building is not allowed to sit in pooled water during wet conditions. If the building is to sit on soil or grass it **MUST** be erected on pressure treated wooden 50mm x 50mm or similar bearers (**These are not supplied in the kit**). Rowlinson Garden Products recommend using pressure treated bearers with all buildings on any type of base.

## 2. Wall panels

Position an end panel and a large side panel on the floor as shown. Note how the panel frames sit on the floor with the panel cladding overhanging the floor edge. Ensure square and secure using 4 x 50mm screws, screw through the frame of the end panel into the frame of the side panel. Position the small back panel next to the first, ensure square and secure them together in the same way. Continue adding the rest of the panels and corner posts as shown in the diagrams using 4 x 50mm screws per join.

 It is recommended to drill pilot holes with a 3mm drill bit for all screws in this section.

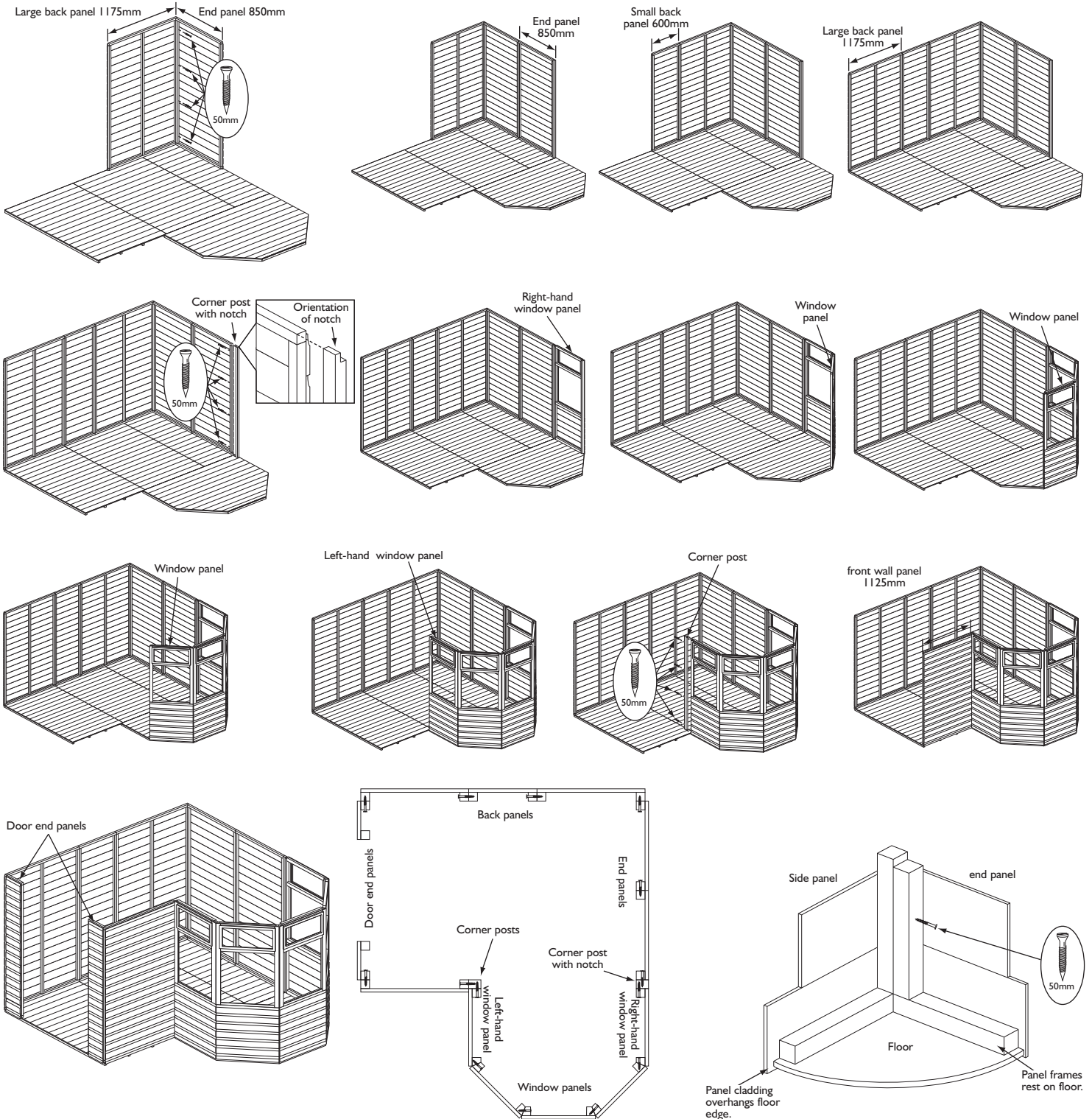

### 3. Apex panels, door header rail and door rebate strips

Place an apex panel on top of the end panels, make sure the bottom shiplap board of the apex panel fits correctly into the shiplap board of the back panel. Secure by using 3 x 50mm screws, screw up through the top frame of the back panel into the bottom frame of the apex panel. Attach an apex panel to the door end in the same way using 3 x 50mm screws. Attach to the door end apex the door header rail using 2 x 50mm screws. Secure it flush to the bottom of the apex framing as shown. The door rebate strips are positioned between the floor and the header rail. Attach the strips flush to the framing of the door end panels using 4 x 30mm nails per strip.



It is recommended to drill pilot holes with a 3mm drill for each screw in this section.

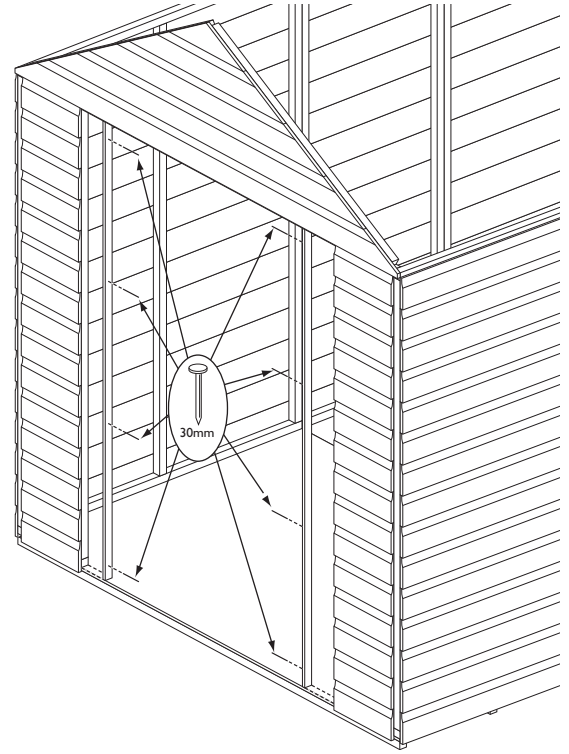
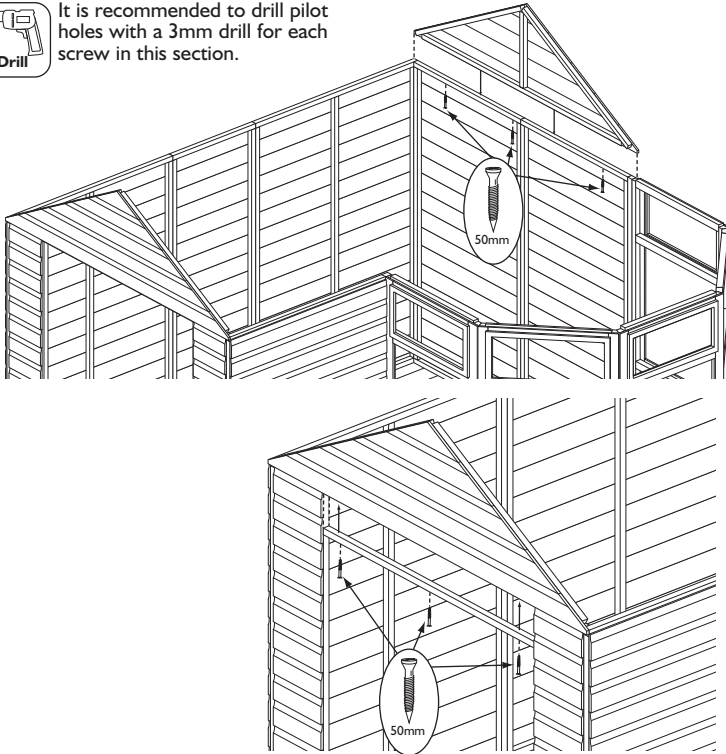

### 4. Secure the walls to the floor

Ensure the panels are sitting square on the floor. Secure using 23 x 63mm screws, screw through the panel frames and floor into the floor joists.



It is recommended to drill pilot holes with a 3mm drill bit for all screws in this section.

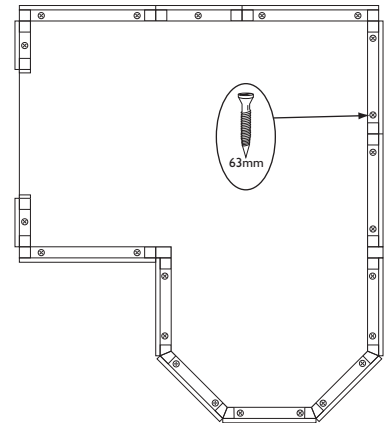
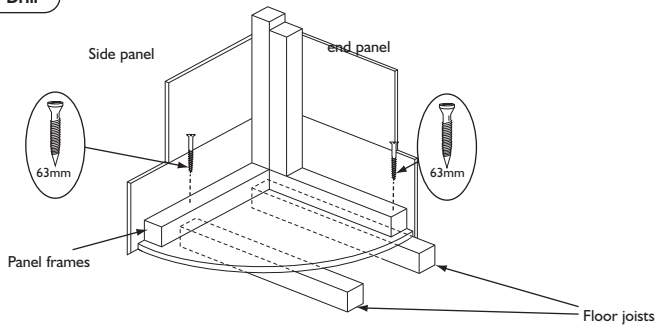

### 5. Roof sections

Build the two large roof sections as shown below by joining the panel frames together, ensure the frames are flush with each other and secure using 2 x 50mm screws for each panel join.



It is recommended to drill pilot holes with a 3mm drill bit for all screws in this section.

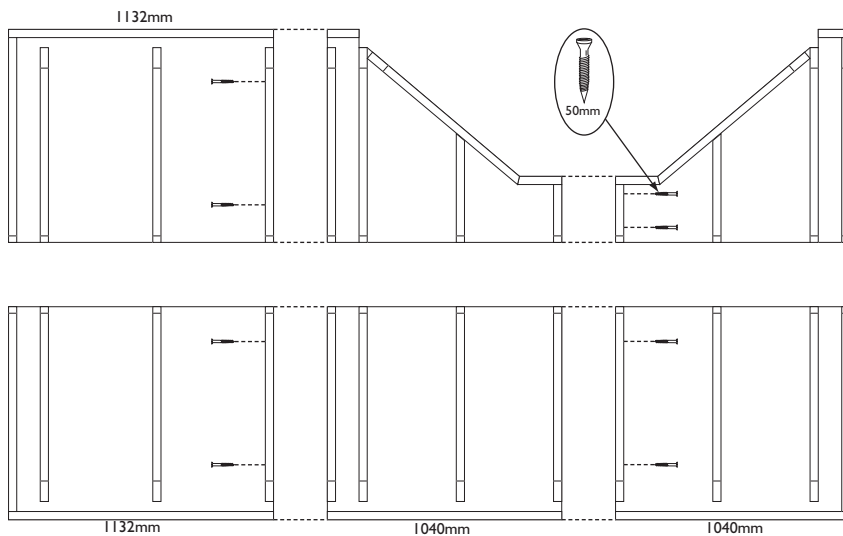

#### Important note

If the potting extension is to be built on the other side it is important to reposition two small framing blocks. Remove the blocks from roof panels and re-attach in the same way to the other panel as shown below. The block must always be on the end of the roof section.

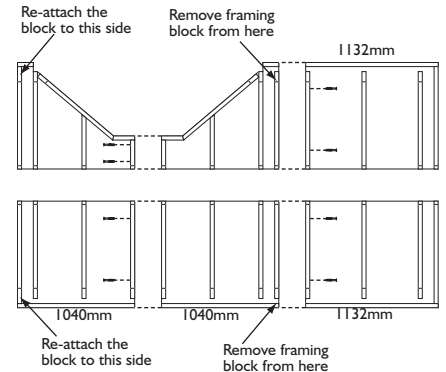

## 6. Fitting the roof part 1

Lift the assembled roof sections onto the building, make sure the top edges are located at the apex and there is an even overhang at each end. From the outside secure the roof section on the back of the building with 6 x 38mm screws as shown, screw through the roof and roof framing into the top of the wall panels. Attach the front roof section in the same way using 4 x 38mm screws. From inside the building attach the roof panel framing at the ends of the building to the apex panels using 4 x 50mm screws. Fix a gusset to the roof rafters using 2 x 30mm nails per gusset.

 It is recommended to drill pilot holes with a 3mm drill bit for all screws in this section.

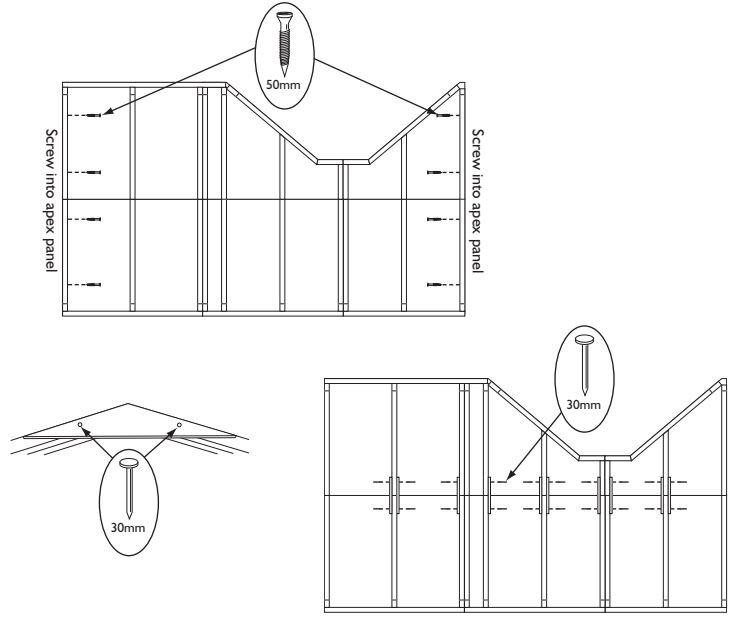
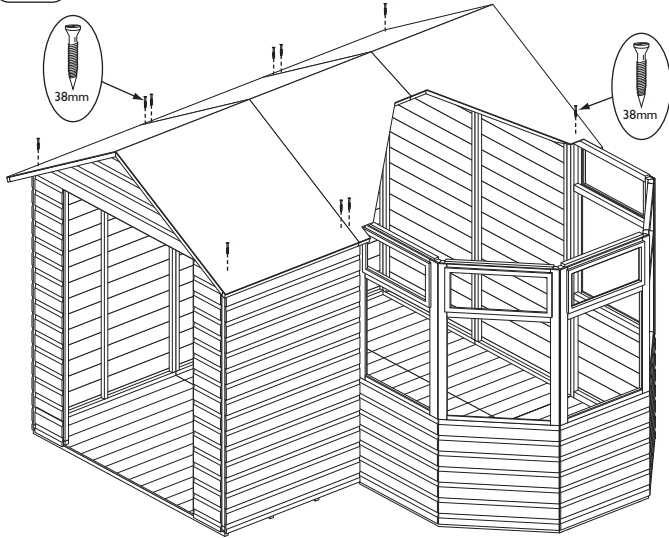

## 7. Fitting the roof part 2

Align to the internal angled roof edges the two roof join covers, with the bottom edges flush to the roof panel framing, fix in place using 4 x 35mm screws. screw through the cover into the angled roof panel framing. Assemble the roof centre block with the internal roof capping, have the block sitting central on the cap except at the angled end where the two components should be flush with each other. Secure the capping to the centre block using 3 x 50mm screws. Screw through the cap into the block as shown. Lift the two hip roof panels onto the wall and angled roof panels as shown. Ensure they are hooked over the wall panels and butted up against the main roof. From inside, fix the panels down to the wall panels using 2 x 50mm screws per panel, screw through the roof panel frame into the top of the wall panels. Using 1 x 38mm screws per hip roof panel screw through the angled roof panels into the ends of the top frame of the hip roof panels. Position the roof centre block between the hip roof panels with the angled end sitting on the main roof, secure in place using 6 x 38mm screws. Screw up through the capping piece into the framing of the hip roof panels. On the outside of the building secure the hip roof panels to the roof join covers using 3 x 32mm screws evenly spaced along the panel.

 It is recommended to drill pilot holes with a 3mm drill bit for all screws in this section.

### Important note

Ensure the bottom edge of the roof join covers are flush to the edges of the main roof panel framing.

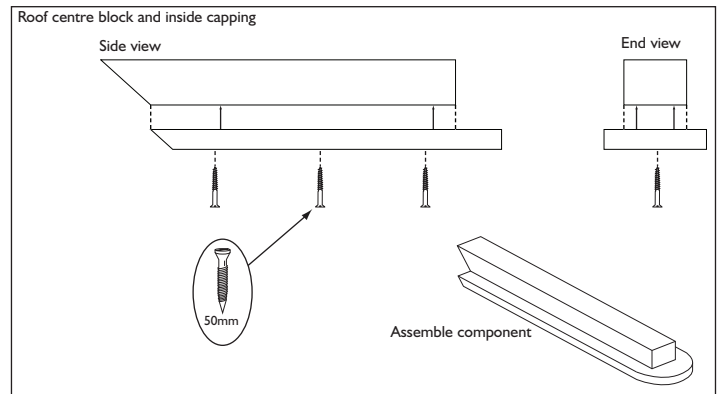
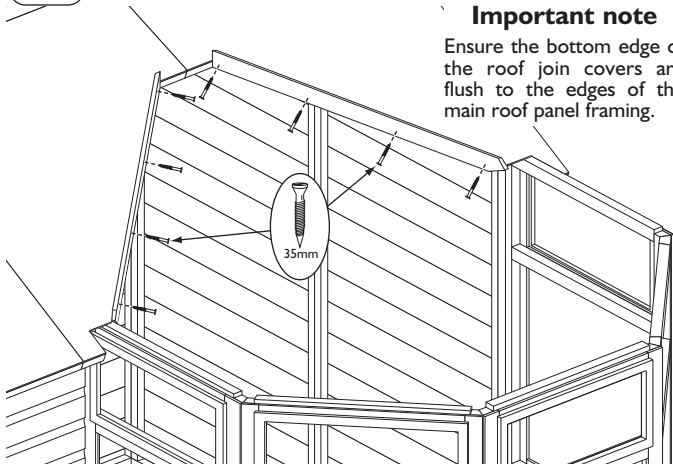

### Important note

From the inside of the building, screw through the main roof into the top roof frame of each hip roof panel using 1 x 38mm screw per roof panel.

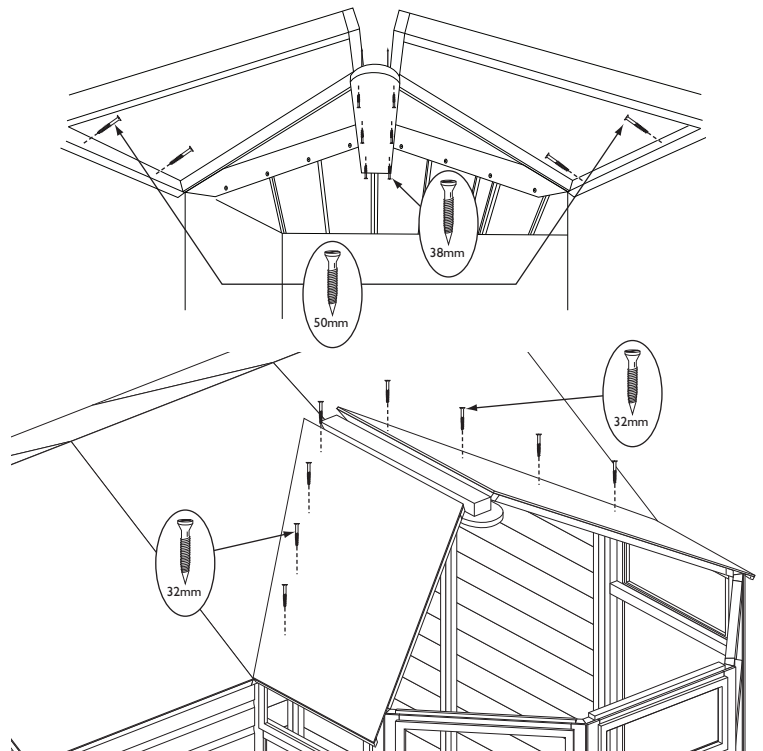
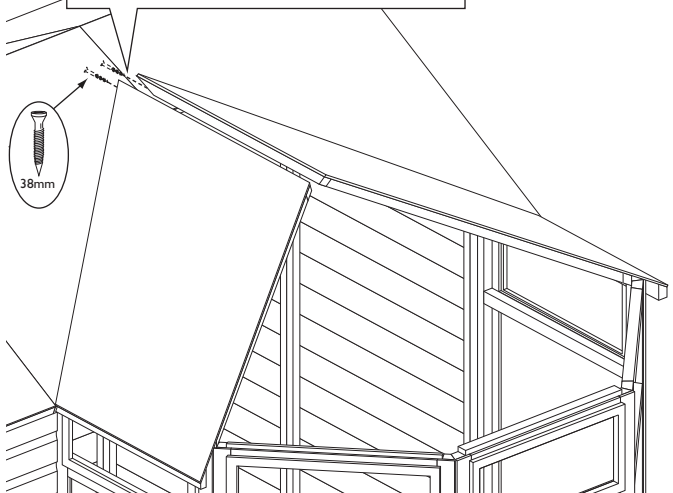

## 8. Fitting the roof part 3

Position the triangular roof panels as shown, loosely secure them together using 2 x 50mm screws per join as shown. Adjust the roof panels to achieve the best fit. Do not fix down to the walls at this stage. On the inside of the building attached the centre roof join cover using 2 x 35mm screws. Screw through the cover into the framing of the main roof. At the roof edge the triangular panels will not lie flush with the hip roof panels, align these panels and secure with 1 x 25mm screw, screw through the bottom frame of the triangular panels into the end of the bottom frame of the hip roof panel.



It is recommended to drill pilot holes with a 3mm drill bit for all screws in this section.

### Important note

Secure panels loosely and adjust to achieve best fit. Do not secure down to the wall panels at this stage.

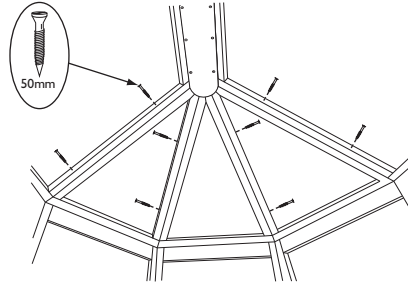

**Important note**  
At these corner points, the triangular roof panels will not lie flush to the hip roof panels. Align these panels and secure using 1 x 25mm screw on each side of the roof. Screw through the bottom frame of the triangular panel into the end of the bottom frame of the hip roof panel.

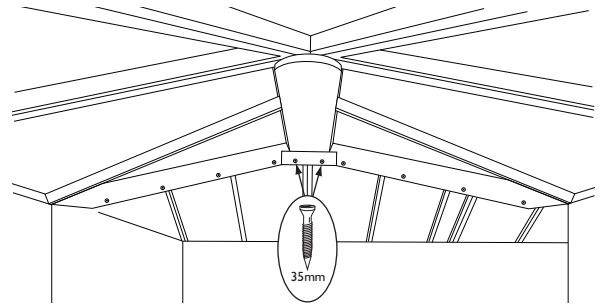
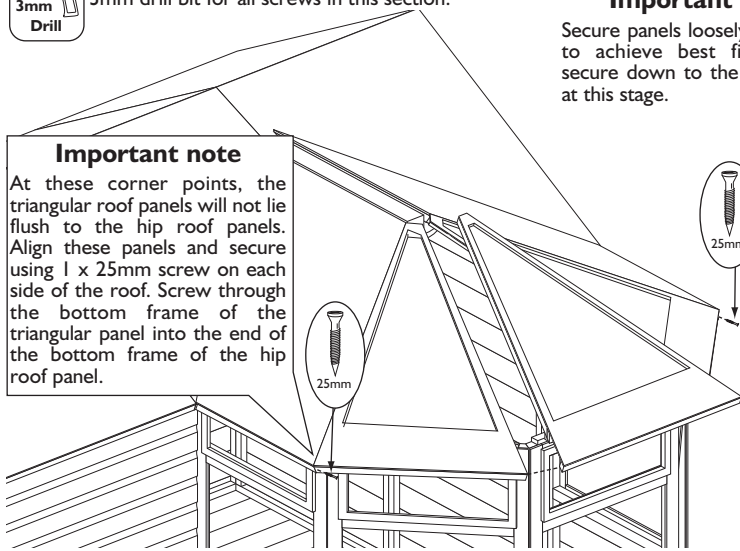

## 9. Doors

Position the doors in the opening and secure each door in place with three T-hinges and 7 x 32mm screws per hinge as shown below. On the inside of the right-hand door secure the tower bolts to the mounting blocks using 4 x 19mm round head screws per bolt. With the doors shut, position a door coverstrip so it overlaps both doors and is flush at the top of the doors, secure only to left-hand door using 4 x 22mm screws. In the same way fix the other door coverstrip flush to the bottom of the door. Fit the pad bolt to the left door between the two coverstrips using 4 x 22mm screws and 2 x 50mm coach bolts, nuts and washers. It will be necessary to drill holes for the coach bolts using a 6mm diameter drill bit. Fit the catch plate to the right door using 2 x 22mm screws and 2 x 50mm coach bolts, nuts and washers, as shown below. Position the turn button just above the left-hand door secure to the apex panel using 1 x 25mm screw.

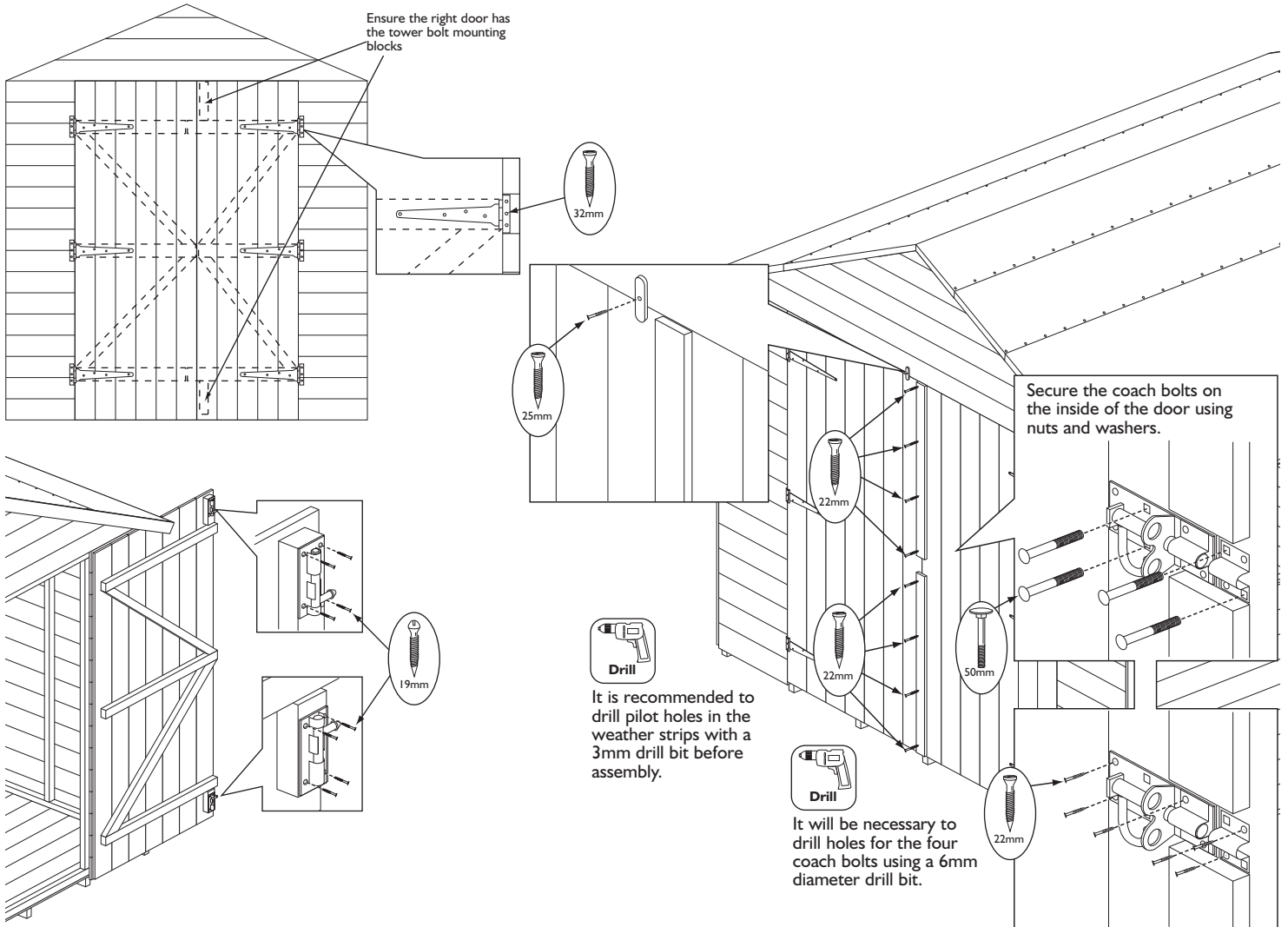

It is recommended to drill pilot holes in the weather strips with a 3mm drill bit before assembly.



It will be necessary to drill holes for the four coach bolts using a 6mm diameter drill bit.

## 10. Roof felt

Before starting this section remove the three triangular roof panels. Cut the 10m felt roll into three equal parts of 3.3m. Place a length of felt over the back roof section. At each end and along the lower edge of the roof leave an overhang of felt enough to cover the felt battens. Fold down the felt along the lower edge and secure to the felt batten using 28 x 10mm felt nails evenly spaced. Tension the felt over the roof and secure along the upper edge using 7 x 10mm felt nails. Dress down the ends and secure using 3 x 10mm felt nails.

### Important note

Only begin this section if you have all the roof panels fitting correctly. It is then necessary to remove the three triangular glazed roof panels to felt the roof. It is not possible to adjust the roof once the felt is in position.

### Important note

Only cut the 10m roll of felt into three equal lengths of 3.3m. Cut all other pieces of felt from the 5m roll

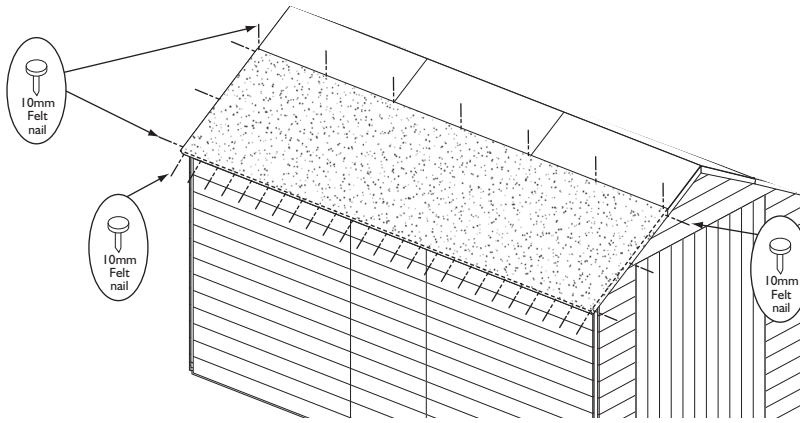

Use a second of the cut pieces (3.3m) and position over the front of the roof. Using the roof as a guide cut along the join between the main roof and the hip roof as shown.

Once the piece has been cut carefully remove this felt piece from the roof.

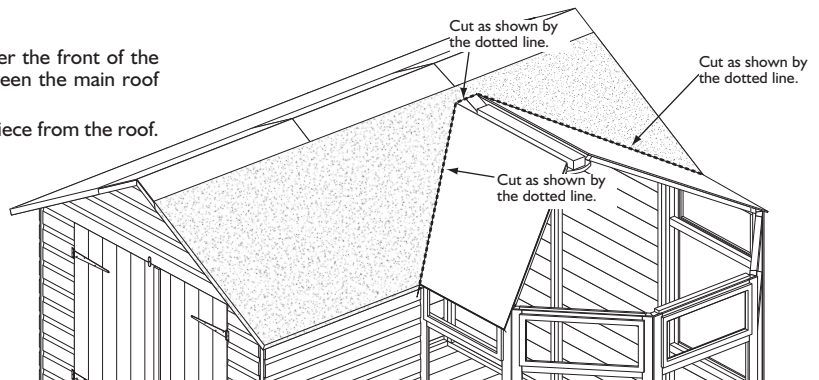

### Important note

Ensure there is enough felt to fold down over the felt battens at each end and along the lower edge of the roof before cutting out the angled section.

Once the felt is cut to shape, take great care to remove it without ripping it.

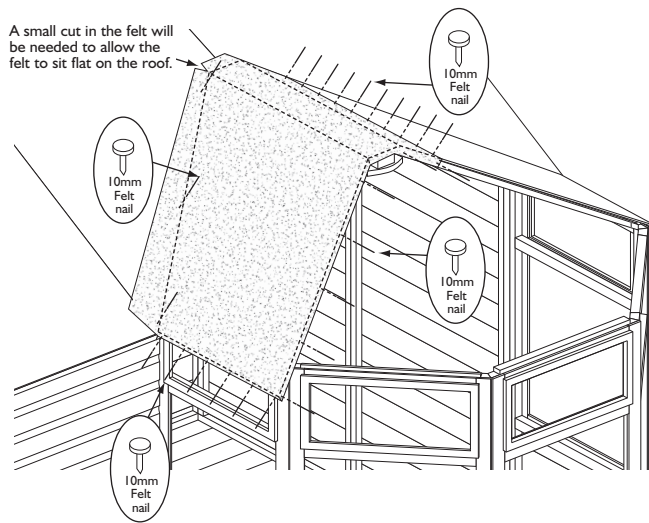

Cut a felt piece from the 5m felt roll long enough to go up and over one side of the hip roof, ensure long enough to cover the bottom frame of the roof panel and about 75mm down the other side hip roof panel. Position the piece as shown fold the felt down over the front roof edge and secure using 7 x 10mm felt nails. Tension the felt over the roof and secure to the felt batten at the lower edge using 6 x 10mm felt nails and the opposite end of the felt using 10 x 10mm felt nails.

Use 3 x 10mm felt nails to attach the felt along the join of the main roof to the hip roof .

Create a second piece of felt for the other side of the hip roof and attach in the same way overlapping the first piece.

With both hip roof felt pieces in place re position the front roof felt and secure in place as shown using 10mm felt nails

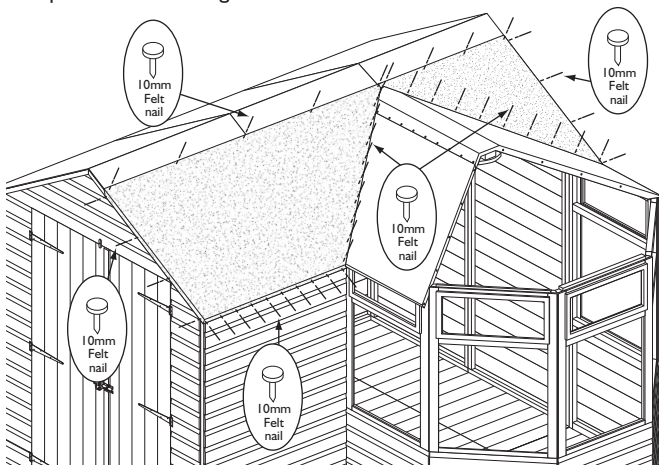

using the third 3.3m piece of felt over the ridge of the roof, ensure that it overlaps all the other felt pieces to ensure no water leaks. Secure down along each long edge using 28 x 10mm felt nails. Dress down the ends and secure at each end using 4 x 10mm felt nails as shown below.

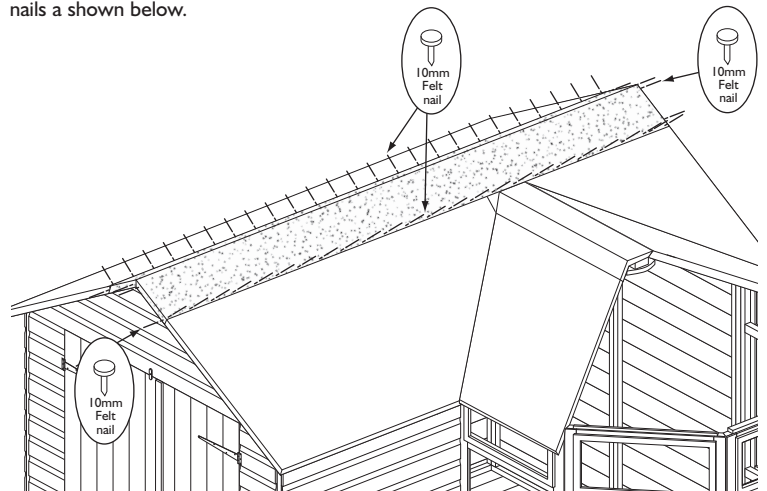

## 11. Replacing and sealing the roof panels

On reassembling the triangular roof panels add a bead of silicon sealant down the edge that butts up to the adjacent panel to ensure a good water tight seal. Secure the panels as before using 2 x 50mm screws per join and fully tighten. Fix the panels down to the wall panels using 2 x 50mm screws per panel, screw through the roof panel frame into the top of the wall panel.

### Important note

As the triangular roof panels are reassemble after felting the roof, add a bead of silicon sealant between all four of the roof panel joins to ensure a good waterproof seal.

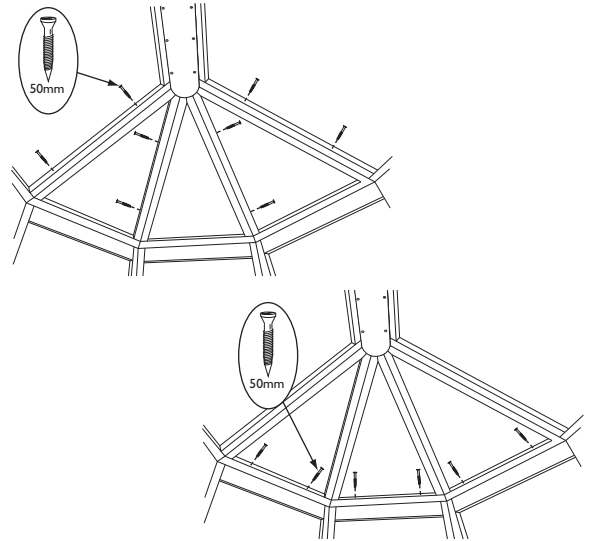
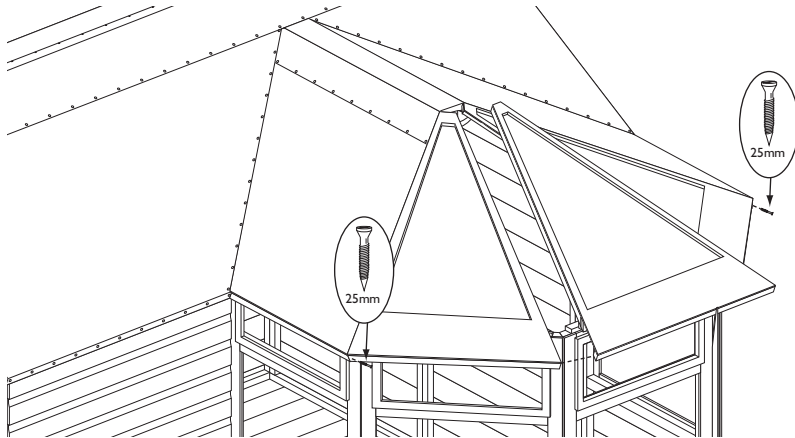

## 12. Completing the roof

Fix the acorn finial centrally to the rounded end of the the roof capping piece as shown using 1 x 50mm screw, screw up through the capping into the base of the acorn finial. Place the capping piece on top of the hip roof extension and screw down through the capping into the centre block using 8 x 50mm screws. Drill 4 pilot holes evenly spaced along the length of each angled roof coverstrip. Apply a good bead of silicon along the underside of the strip. Position a strip over each of the roof panel joins as shown, tucking each one under the top cap and have the pointed end finishing flush to the edge of the roof, Secure each strip with 4 x 25mm screws.

 It is recommended to drill pilot holes with a 3mm drill bit for all screws in this section.

### Important note

Add a bead of silicon sealant to the underside of each strip just prior to positioning them and fixing them down.

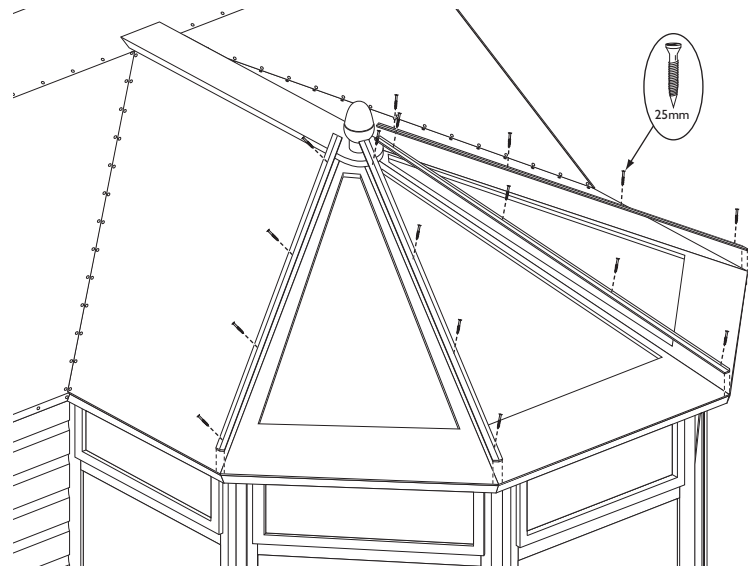
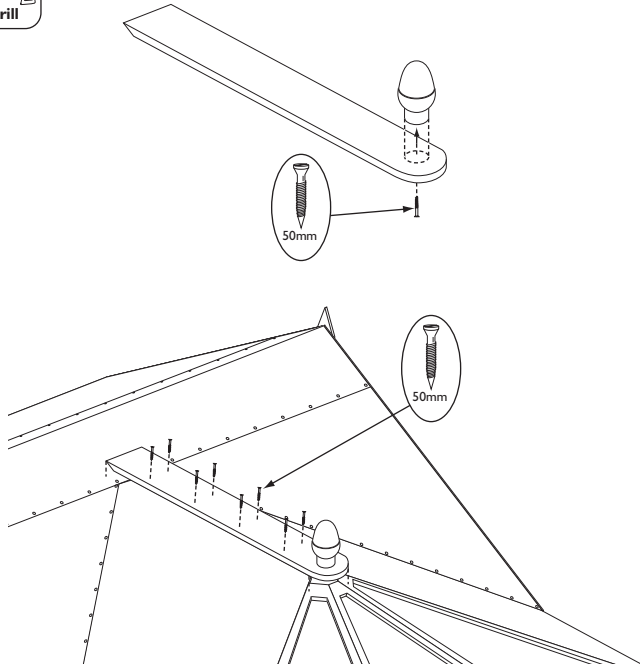

## 13. Potting Benches

Position the potting table underneath the three middle windows as shown, align level with the window cill and secure underneath the table using 6 x 50mm screws screw through the framing of the potting table into the window cill. Position a side potting table under each of the remaining windows attach each with 2 x 50mm screws to the window cill and secure to the main potting table using 2 x 50mm screws. The four potting table legs are secured underneath the tables as shown using 1 x 50mm screw at the top of each leg, screw though the leg into the framing of the table. Ensure each leg is vertical and secure to the floor using a Metal L-bracket and 4 x 25mm screws per bracket.

 It is recommended to drill pilot holes with a 3mm drill bit for all screws in this section.

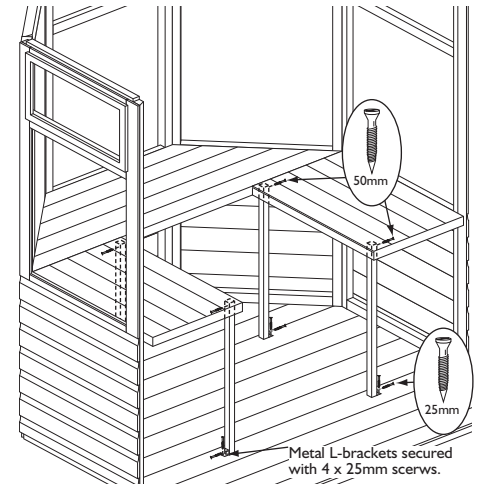
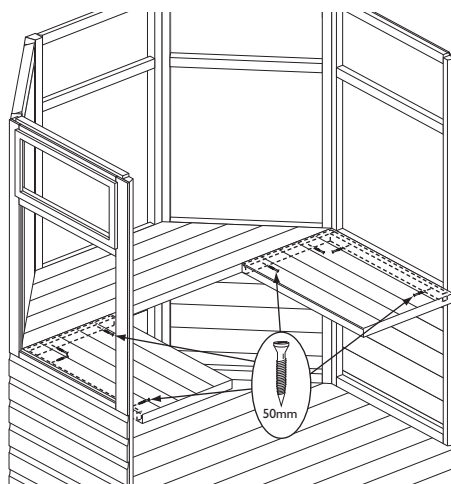
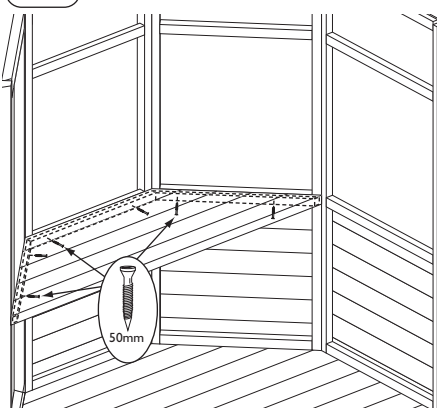

Metal L-brackets secured with 4 x 25mm screws.

#### 14. Corner/joint coverstrips

Secure the seven corner/joint coverstrip and the four angled corner coverstrips in the positions shown in the second diagram. Each strip is fixed using 4 x 30mm nails evenly spaced along the length of the strip

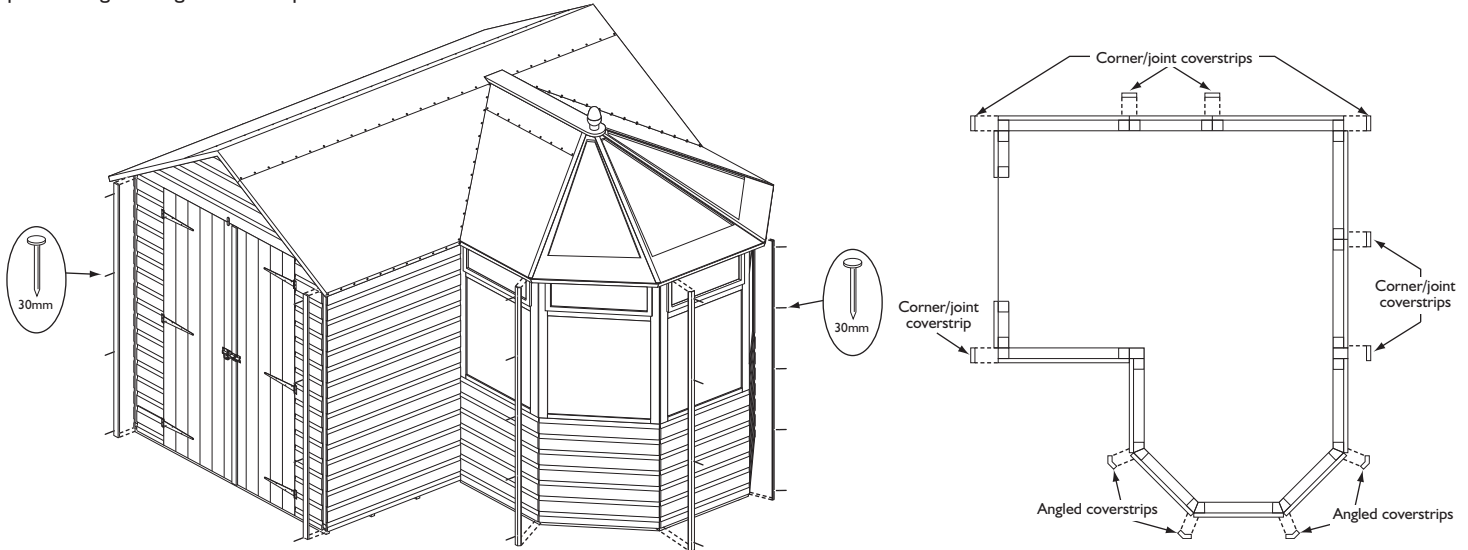

#### 15. Bargeboards and finials

At both ends of the main apex roof of the building secure two bargeboards, ensure that the top edges are flush with the roof line and the boards meet evenly at the apex secure using 4 x 30mm nails per board. Attach a finial centrally over the join between the two bargeboards using 2 x 30mm nails. Position the front bargeboard on the roof edge above the front wall panel, secure using 4 x 30mm nails. The remaining bargeboards are positioned around the roof edge of the side extension, each one is fix using 3 x 30mm nails.

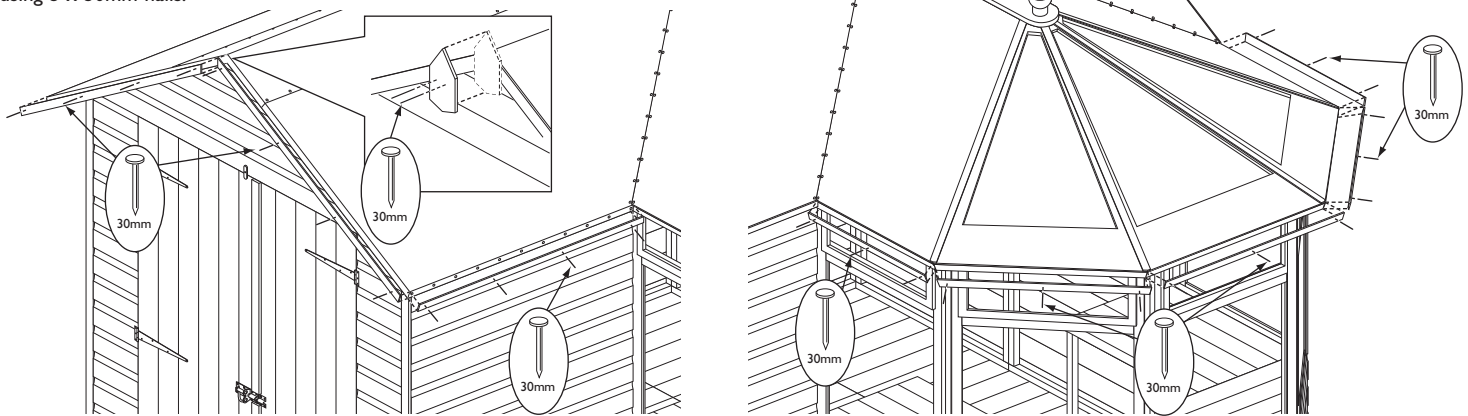

#### 16. Glazing

It is recommended that a waterproof sealant is applied around the edge of the glazing before fitting. Place window pane on the inside of the window frame, nail the beading into position. For the large windows using 4 x 25mm nails for each vertical bead and 3 x 25mm nails for each horizontal beading. For the small windows use 2 x 25mm nails for the vertical beading a 3 x 25mm nails for the horizontal beading.

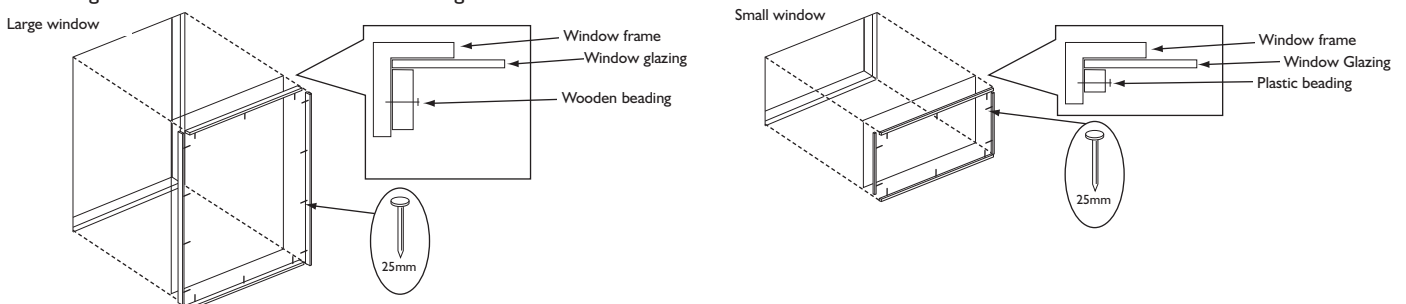

#### Important information - retain for future reference

Shiplap buildings come ready stained but this is only a preparatory treatment. To **VALIDATE** the guarantee, the building must be properly treated with a recognised external wood preserver **WITHIN 3 MONTHS** of assembly and **RE-TREATED ANNUALLY** thereafter. Adequate provision must be made to ensure ground contact is avoided and air is able to circulate underneath the building.

Placing the building on a concrete pad or slab base is acceptable provided that the building is not allowed to sit in pooled water during wet conditions.

If the building is to sit on soil or grass it **MUST** be erected on pressure treated wooden 50mm x 50mm or similar bearers (**These are not supplied in the kit**).

Rowlinson Garden Products recommend using pressure treated bearers with all buildings on any type of base.

#### Timber Information.

As timber is a natural material, there are certain weather conditions that may affect the materials properties. In times of excessive dry spells the material may lose some of its internal moisture causing a certain degree of shrinkage on a panel and in periods of excessive rain there will be a certain amount of swelling throughout the wooden panels. This process can not be avoided. If you have problems with certain boards shrinking in dry spells try to decrease the amount of direct sunlight on the building or the amount of air passing over the building. During hot spells spray water directly onto the panels with the aid of a garden hose.

If in doubt of any aspect regarding the assembly, use or safety of your building please contact us:

**Help Line (Normal Office Hours) 01829 261121**

ROWLINSON GARDEN PRODUCTS LIMITED  
Green Lane  
Wardle Nr.Nantwich  
Cheshire  
CW5 6BN

We constantly improve the quality of our products, occasionally the components may differ from the components shown and are only correct at time of printing. We reserve the right to change the specification of our products without prior notice.

**2009 © Rowlinson Garden Products Ltd**